

High Precision Pressure Transducer

Series 8201
Version H

Code:	8201 H EN
Delivery:	ex stock/3 weeks
Warranty:	24 months

CAD data 2D/3D for this sensor:
Download directly at www.traceparts.com
Info: refer to data sheet 80-CAD-EN



Now with
USB interface, up to
16 Bit / 2500 measurements/s

- Measuring ranges from 0 ... 30 bar to 0 ... 500 bar
- Accuracy < 0.1 %
- Output 0 ... 5 V, 0 ... 20 mA or 4 ... 20 mA available
- Suitable for liquid and gaseous media
- Can be used for dynamic and static measurements
- Made of stainless steel, reliable and sturdy
- Standardized sensitivity to 1.0 mV/V

Application

The high precision pressure transducers series 8201 H are of a sturdy and compact construction. Due to their resistance against mechanical strain they enable exact measurements. Therefore they can not only be used in laboratories of research and development but they are also very suitable for process quality control in the industrial sector. The material and the strain gauges are the guarantees of a long-term stability, a high degree of reliability and insensibility against aggressive mediums measured in liquid or in gaseous condition.

The construction of the transducer is realized without moving parts so that it is highly insensitive against shock loads and vibrations.

For critical cases of application a set of PTFE rings is available to seal the pressure port. Critical media may cause problems at the welding seams of the sensor body, please contact us. Customized models are available on request.

Description

The high precision pressure transducers can be configured with a lot of options, the standard version is available ex stock.

The medium is led via the pressure port into the measuring chamber, which is closed with a welded diaphragm, the measuring element. The diaphragm is deformed in proportion to pressure exercised. On the reverse side of the diaphragm a four-legged film strain gauge bridge is applied. The physical value pressure is converted into an electrical change of resistance. The measuring of pressure is performed against ambient pressure, the space behind the diaphragm is in connection with the reference atmosphere.

Each transducer is available with an internal amplifier, a so-called pressure transmitter with a voltage or a current output. The amplifier's input is immune against polarity reversal. The output is safe against over-voltage. Thanks to the design of the amplifier circuit, inexpensive uncontrolled mains adapter may also be used. The electrical connection is made by a housed and MIL specified connector. The pressure port is formed by a M 16 x 1.5 metric female thread with sealing ring groove. With the help of adapters, part of our product range, the pressure port can be changed.

Technical Data

Order Code	Measuring Range	Resonance Frequency [kHz]
8201-5030-H021A	0 ... 30 bar	5.0
8201-5050-H021A	0 ... 50 bar	7.0
8201-5100-H021A	0 ... 100 bar	10.0
8201-5200-H021A	0 ... 200 bar	12.5
8201-5300-H021A	0 ... 300 bar	15.0
8201-5500-H021A	0 ... 500 bar	20.0

Electrical values

Bridge resistance: full bridge circuit of foil strain gauge		350 Ω, nominal
Calibration resistor:		100 kΩ
The bridge output voltage resulting from a shunt of this value is shown in the test certificate.		
Excitation voltage:	recommended maximum	5 V DC 10 V DC
Nominal sensitivity:	standardized;	1.0 mV/V ± 0.25 %

Environmental conditions

Range of operating temperature:	- 30 °C ... 120 °C
Nominal temperature range:	0 °C ... 70 °C
Influence of temperature on zero:	≤ ± 0.005% F.S./K
Influence of temperature on sensitivity:	≤ ± 0.005% Rdg./K

Mechanical values

Combined error consisting of non-linearity, hysteresis and variation:		< ± 0.1 % F.S
Kin of measurement:	measurement against atmosphere	
Dead volume:		5.8 cm ³
Volume change:		negligibly small
Overload:	measuring range ≤ 0 ... 300 bar measuring range ≥ 0 ... 500 bar	50 % over capacity 25 % over capacity
Burst pressure:		>100 % over capacity
Dynamic performance:	recommended maximum	50 % of capacity 70 % of capacity

Design:

Diaphragm pressure transducer with hermetically sealed measuring chamber (without internal sealing elements).

Material: stainless steel, 1.4548.9

Pressure port: internal thread M 16 x 1.5

Sealing:

Sealing of the transducer is ensured by the thrust and O-ring which is included in scope of delivery. For critical applications there is also a Teflon-coated Viton® O-ring with thrust ring available, see accessories.

Mounting torque: max. 3 Nm

Electrical connection:

6 pin bayonet model connector Souriau 851 07A 10 - 6 P

Wiring code:	pins A + B	excitation voltage	positive
	pins C + D	excitation voltage	negative
	pins E	signal output	negative
	pins F	signal output	positive

Dimensions: refer to dimensional drawing

Weight: approx. 420 g ... 650 g

Protection class: acc. to EN 60529 IP65

Mating plug: model 9945

Souriau 851-06E-C-10-6S or Amphenol 62-GB-16F-10-6S included in scope of delivery

Technical Data of the Internal Amplifier

Excitation voltage: 15 ... 30 V

Current consumption: max. 65 mA

Connection technology: 3 wire

Output resistance: 200 Ω (15 V) ... 800 Ω (at 24 V)

Cut-off frequency: (- 3 dB) 1 kHz

Range of operating temperature: 0°C ... 60°C

Wiring code:

pin	A	excitation voltage	positive
pin	B	ground	
pin	C	ground	
pin	D	signal output	positive
pins	E + F	not connected	

Dimensions: see dimensional drawing

Dimensional drawing model 8201 H

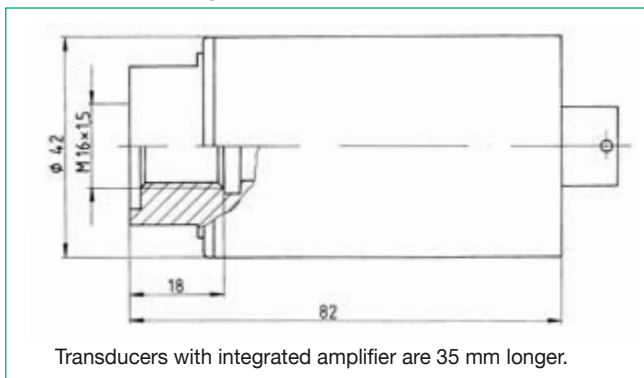

The CAD drawing (3D/2D) for this sensor can be imported online directly into your CAD system.

Download via www.burster.com or directly at www.traceparts.com. For further information about the burster traceparts cooperation refer to data sheet 80-CAD-EN.

Order Information

High precision pressure transducer, measuring range 0 ... 200 bar, integrated amplifier for 0 ... 5 V

8201-5200-H331A

Accessories

Thread adapter, material 1.4571, for following connecting threads	
External thread M 16 x 1.5	Model 8281
External thread G 1/2" A	Model 8283
External thread R 1/4" (max. 500 bar)	Model 8285
External thread M 20 x 1.5	Model 8286
External thread 3/4 - 16 UNF	Model 82822
External thread M 14 x 1.5	Model 82825
Internal thread 3/4 - 16 UNF	Model 82827
Internal thread 1/4 - 18 NPT (max. 500 bar)	Model 82829
Standard sealing ring set (included in scope of delivery)	Model 82911
PTFE sealing ring set for critical applications;	
Teflon-coated Viton® thrust and O-ring	Model 82910

Connecting Cables

for transducers with plug-in connector and bridge output, complete with connector and socket, 6 wire, shielded, bending radius > 5 mm, PVC insulation, standard length of 3 m

for all burster indicators table version with 12 pin connection

Model 9911

for process indicator 9162 **Model 99545-564C-0100030**

with open, color coded and tinned cable ends;

for sensors with internal amplifier **Model 99545-000D-0160030**

Other cable lengths and customized cables on request.

Option

Option 33	internal amplifier for voltage output 0...5 V
Option 37	internal amplifier for current output 0...20 mA
Option 39	internal amplifier for current output 4...20 mA
Option 41	internal USB interface, resolution 16 bit, 2500 measurements per second
Option DKD	Calibration certificate according to standard DKD-R 6-1 with 21 measuring points in 10 % increments for rising and falling pressure.
Option WKS	Manufacturer calibration certificate with 11 measuring points in 20 % increments for rising and falling pressure, done twice.