

Miniature Pressure Sensor

Model 8112

Code:	8112 EN
Delivery:	ex stock/6 weeks
Warranty:	24 months

CAD data 2D/3D for this sensor:
Download directly at www.traceparts.com
Info: refer to data sheet 80-CAD-EN



- Measuring ranges from 0 ... 10 bar up to 0 ... 350 bar
- For static and dynamic measurements
- Temperature range up to 220 °C
- Membrane diameter 8.0 mm
- Absolute pressure measurement optional
- Protection class IP67 optional

Application

Due to their small dimensions, miniature pressure sensors can cover a vast range of applications. They are suitable for both gaseous and liquid media, and can be used for both static and dynamic measurements. Their main fields of application are found in aeronautical and space engineering, in medicine, in food processing, in laboratories and in precision mechanics. The versions offered allow the user to adapt them optimally to the system being examined, i.e. to be able to measure pressure in places where this can no longer be done with sensors of normal size, whether for reasons of space or of weight, because the process volumes are so low, or because high natural resonance frequencies are required. They are also particularly suited for applications where temperatures up to 220 °C are reached.

Fields of application:

- ▶ Tool making
- ▶ Aeronautical engineering
- ▶ Food processing
- ▶ Special purpose machinery manufacturing
- ▶ Gear manufacturer

Description

Design

The measuring element of the miniature pressure sensors consists of a clamping ring and a membrane, manufactured as one part. It is bonded to the sensor housing in a laser welding process. Both parts are made of stainless steel. A special technology keeps the distorting forces on the sensor housing, caused inevitably when it is screwed into place, away from the measuring membrane. As a result, the offset in the zero point caused by the process of assembling the sensor is reduced as far as possible.

The bending forces resulting from the pressure on the membrane are converted into an electrical signal by means of silicon strain gauges wired as a full bridge. In combination with the full bridge circuit, these ensure a low temperature coefficient and high temperature stability. The sensors can be energized by direct or alternating voltage.

Mode of measurement

The pressure measurement is either absolute or relative to atmosphere. If the sensor is designed to measure pressures relative to atmosphere, the ambient air (or the reference gas) must be dry, clean and non-corrosive. Optionally, the sensor can be obtained in a version that delivers absolute measurements.

Output voltage

The output voltage is quoted in mV/V – millivolts per volt of supply – and is stated with reference to the nominal pressure of the unit. The value of the output signal depends on the design of the membrane, and is proportional to the pressure exerted on it. The relationship between the voltage applied to the bridge and the voltage output is, again, directly proportional. The sensors can be energized by direct or alternating voltage.

Technical Data

Order Code	Measuring Range
8112-5010	0 ... 10 bar
8112-5020	0 ... 20 bar
8112-5050	0 ... 50 bar
8112-5100	0 ... 100 bar
8112-5200	0 ... 200 bar
8112-5350	0 ... 350 bar

Electrical values

Bridge resistance, input:	530 Ω, nominal
Bridge resistance, output:	350 Ω, nominal
Nominal excitation voltage:	max. 10 V DC
Nominal sensitivity:	1.0 mV/V, nominal
Insulation resistance:	at 50 V DC ≥ 100 MΩ

Environmental conditions

Range of operating temperature:	- 75 °C ... 220 °C
Nominal temperature range, compensated:	0 °C ... 150 °C
Influence of temperature on zero:	< ± 1.0 % F.S./50 K
Influence of temperature on sensitivity:	< ± 1.0 % Rdg./50 K

Mechanical values

Non-linearity:	
measuring range 0 ... 10 bar	< ± 0.35 % F.S.
measuring range ≥ 0 ... 20 bar	< ± 0.25 % F.S.
Hysteresis:	
measuring range 0 ... 10 bar	< ± 0.35 % F.S.
measuring range ≥ 0 ... 20 bar	< ± 0.25 % F.S.
Error of variation:	< ± 0.2 % F.S.
Kind of measurement:	pressure measurement against atmosphere
Volume change:	negligibly small
Overload:	50 % over capacity
Burst pressure:	200 % over capacity
Natural frequency:	25 kHz ... 150 kHz
Dynamic load:	
recommended	70 % of capacity
maximum	100 % of capacity
Design:	flush mounted, welded diaphragm
Material:	diaphragm and housing made of stainless steel
Pressure connection:	external thread M 10 x 1
Sealing:	self centering sealing ring included in scope of delivery

Mounting torque:	
recommended	change of zero-point and sensitivity < 1 % 10 Nm
maximum possible	15 Nm

Electrical connection:
4 wire, Teflon isolated, shielded cable, integrated bend protection, color coded, with open ends, diameter approx. 3 mm, length 2 m

Wiring code:		
red	excitation voltage	positive
black	excitation voltage	negative
white	signal output	negative
green	signal output	positive

Dimensions:	see scale drawing	
Weight:	without / with cable ca 20 g / 55 g	
Protection class:	acc. to EN 60529	IP50

Dimensional drawing model 8112

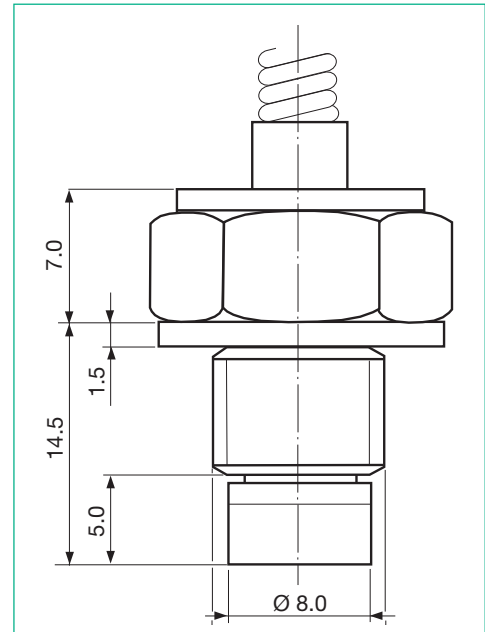

The CAD drawing (3D/2D) for this sensor can be imported online directly into your CAD system.

Download via www.burster.com or directly at www.traceparts.com. For further information about the burster traceparts cooperation refer to data sheet 80-CAD EN.

Order Information

Miniature pressure transducer, measuring range 0 ... 100 bar, absolute measurement, protection class IP67 **8112-5100-T0007000**

Accessories

Sealing ring, thickness 1.5 mm **Model 8112-Z001**

Options

Measurement of absolute pressure **...-Txxxxxxx**
Protection class IP67 **...-xxxx7xxx**

Manufacturer Calibration Certificate (WKS)

Standard Manufacturer calibration certificates quoting 11 points in 20 % increments for rising and falling pressure; each point is approached twice. Also available with evaluating electronics as a measurement chain.